

JUXTA W Series General Specification

Model WX3□-FP (Variable software type)
Programmable Unit

JUXTA

1. GENERAL

This is a variable type computing unit which accepts two mV signal inputs from various converters and outputs each 2-point input computed result (after delivery, the function is determined by freely creating programs by the customer using the handy terminal [JHT-100]) as an isolated DC voltage or current signal.

2. SPECIFICATIONS

Model No.	WX3A-FP, WX3V-FP
Input signal	mV signal: 2 points
Measuring range	- 2 to 10 mV (There is accuracy limitation for spans of more than 3 mV and less than 10 mV.) - 10 to 50 mV (For span of more than 10 mV) - 50 to 250 mV (For span of more than 50 mV) - 100 to 1250 mV (For span of more than 250 mV) (*1)
Input resistance	1 MΩ (At power failure: More than 3 KΩ)
Output signal	4 to 20mA, 2 to 10mA, 1 to 5mA, 0 to 20mA, 0 to 16mA, 0 to 10mA or 0 to 1mA DC 0 to 10mV, 0 to 100mV, 0 to 1V, 0 to 10V, 0 to 5V, 1 to 5V or -10 to +10V DC
Basic accuracy	±0.2% of measuring span (Only when input (%) = Output (%))
Signal insulation	Between any of input signal, output signal, power supply circuits and grounding
Insulation resistance	Between any of input, output and power (DC driven) Between any of input, output, power and grounding (AC driven) 100 MΩ/500 V DC
Dielectric strength	Between input and output/power: 1500 V AC/min. and between output and power: 500 V AC/min. (DC driven) Between any of input, output, power and grounding: 1500 V AC/min. (AC driven)
Power supply voltage	85 to 264 V AC 47 to 63 Hz, or 24 V DC ± 10%
Ambient temperature/humidity	0 to 50°C (32 to 122°F) and 5 to 93% relative humidity (No condensation)
Effect of ambient temperature	±0.2% of span for 10°C (50°F) change
Effect of power supply voltage	±0.2% of span for 85 to 264 V AC or 24 V DC ±10% variation
Power consumption	100 V AC, 7.0 VA (voltage output) and 100 V AC, 8.5 VA (current output) 24 V DC, 60 mA (voltage output) and 24 V DC, 82 mA (current output)
Dimensions	72 (2.83") H × 48 (1.89") W × 127 (5.00") D mm (inch)
Weight	Approx. 150 g (DC driven), 280 g (AC driven)
Accessories	Tag number label : 1 sheet Mounting blocks: 2 pcs.

(*1) Specify measuring range from □ to □ mV.

Range accuracy for span of less than 10 mV: $0.2 \times 10 / (\text{mV input span}) \%$

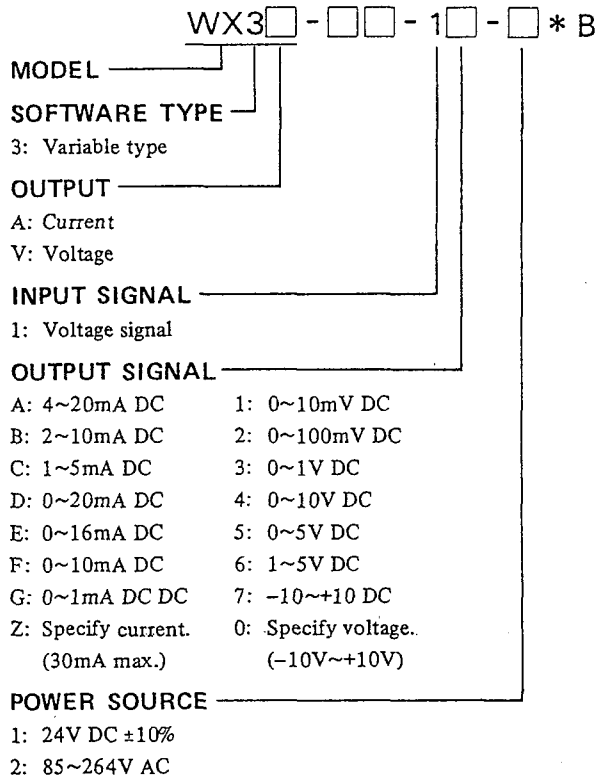

Ordering Information

Input Measuring Range		
Range name	Allowable min. span	Allowable Measuring Range
HH	250 mV	-100 ~ 1250 mV
H	50 mV	-50 ~ 250 mV
L	10 mV	-10 ~ 50 mV
LL	3 mV	-2 ~ 10 mV
However, accuracy of less than 10 mV span is $0.2\% \times \frac{10 \text{ mV}}{\text{Input span (mV)}} (\%)$		
Recommended Input Range		
Voltage signal	0 ~ 10 mV DC 0 ~ 100 mV DC 0 ~ 1V DC	

OUTPUT RESISTANCE AND LOAD RESISTANCE

Output Signal	Load Resistance	Output Impedance
4 to 20mA DC	0 to 750Ω	5MΩ or more
2 to 10mA DC	0 to 1500Ω	
1 to 5mA DC	0 to 3000Ω	
0 to 20mA DC	0 to 750Ω	
0 to 16mA DC	0 to 900Ω	
0 to 10mA DC	0 to 1500Ω	
0 to 1mA DC	0 to 15kΩ	

Output Signal	Load Resistance	Output Impedance
0 to 10mV DC	100kΩ or more	100Ω or less
0 to 100mV DC		
0 to 1V DC	2kΩ or more	1Ω or less
0 to 5V DC		
1 to 5V DC		
0 to 10V DC	10kΩ or more	
-10 to +10V DC		

Subject to change without notice for grade up quality and performance